

## CONTROLLER

The controller provides interfacing from associated access control devices to activate the electrical road blocker. All inputs & outputs are controlled through a 24 volt control board with all necessary with most access control devices on the market.

## TECHNICAL DATA

- Height of raised obstacle: 30mm
- Length of obstacle: 2200mm - 3500mm (Optional length on request).
- Width of obstacle: 580mm
- Motor: Single Phase asynchronous type.  
500W 1440rpm.
- Power supply: 230V Single phase 50/60Hz
- Reduction gear box: Worm-screw type, life-lubricated, ratio of reduction 6:1
- Power consumption: In stand-by mode 100W  
In operation 800W
- Operation temperature: -20 to 80 degree celsius
- Net weight: MODEL A: 300KG.  
MODEL B: 340KG.
- Operation speed: 3 sec.
- Overall dimensions: Model A----- 2200mm  
Model B----- 3140mm

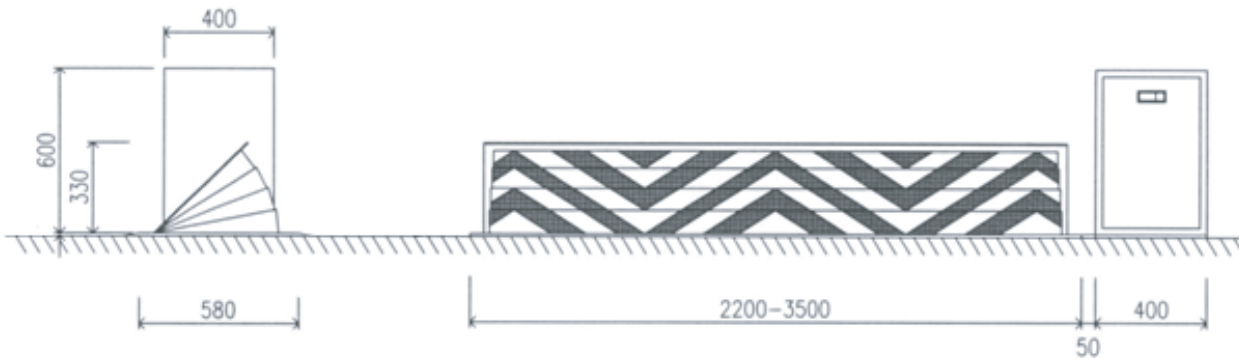

**ACE AUTOMATIC SYSTEM CO.**  
(Wholly Owned By Mark Gain Investment Ltd.)

日電自動系統(香港)公司