

FEATURES

- Emergency intercom button.
- High resolution LCD display panel with Chinese & English texts.
- A compatible PC, cash register & color monitor.
- An interface communication linkage of equipment between Octopus reader & PC.
- Real time validity display at entrance.

TECHNICAL DATA

- Power consumption: 60W
- Weight: 30KG.
- Voltage: AC 200V
- Frequency: 50-60Hz
- R.H.: 20%-98%
- Temperature: 0 to 50 degree celsius (Accessories may be needed below 0 degree celsius)

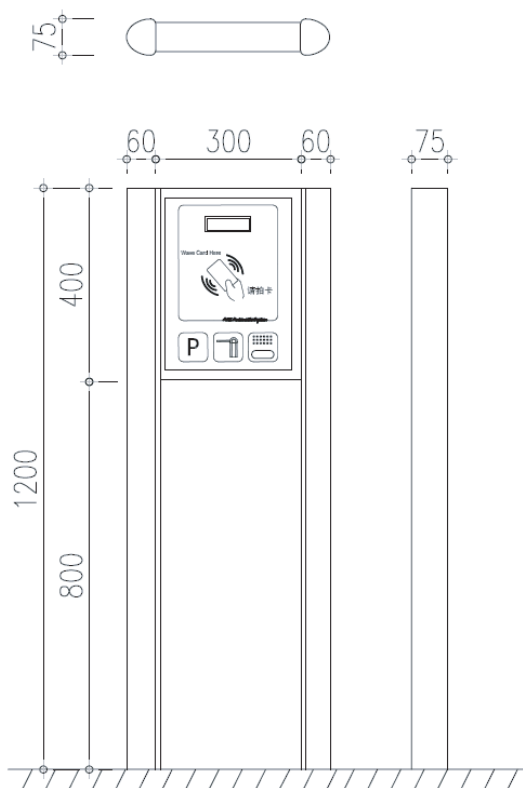

ACE AUTOMATIC SYSTEM CO.
(Wholly Owned By Mark Gain Investment Ltd.)
日電自動系統(香港)公司